

RoHS COMPLIANT

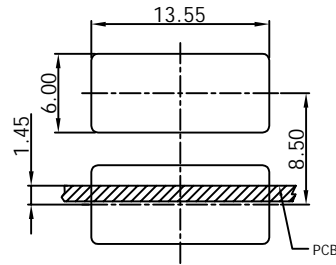

RECOMMEND PANEL CUTOUT

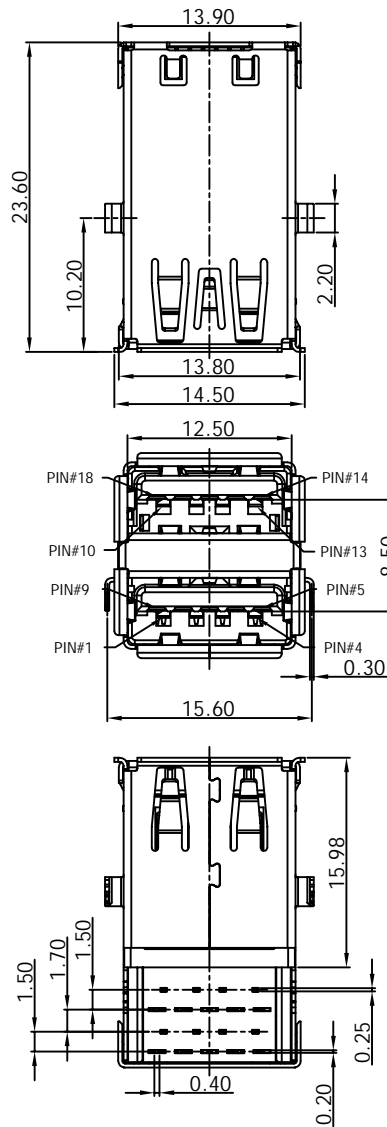
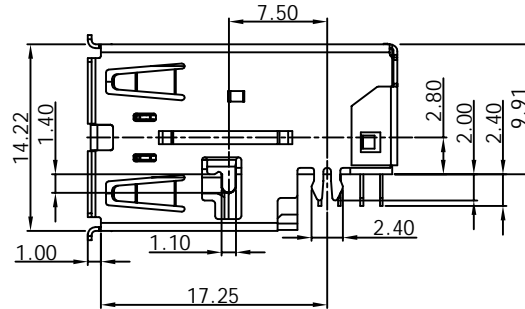

Part number Information: DW-MU3-SA18081-XX XX-01

- Terminal Plating
- 01: Gold Flash Plating on Mating Area
- 03: 3u" Gold Plating on Mating Area
- 05: 5u" Gold Plating on Mating Area
- 15: 15u" Gold Plating on Mating Area
- 30: 30u" Gold Plating on Mating Area
- TP: Tray Packing
- TR: Tape Reel
- Series
- 01-99

NOTES:

1. MATERIAL:

1.1 HOUSING & COVER: HIGH TEMPERATURE THERMOPLASTIC, GLASS FIBER FILLED, UL94V-0, COLOR : BLUE.

1.2 CONTACTS 5PIN: BRASS,

1.3 CONTACTS 4PIN: PHOSPHOR BRONZE,

1.4 SHELL: SUS201.

1.5 ISOLATED: SK7.

2. FINISH:

2.1 CONTACTS: 30u" MIN GOLD PLATED ON CONTACT AREA, 100u" MIN. MATTE-TIN PLATED ON SOLDER TAIL, 50u" MIN. NICKEL UNDERPLATED OVERALL.

2.2 SHELL: [50u" MIN. NICKEL PLATED OVERALL.

2.3 ISOLATED: 50u" MIN. NICKEL PLATED OVERALL.

3. REFLOW SOLDER CAPABLE TO 260°C

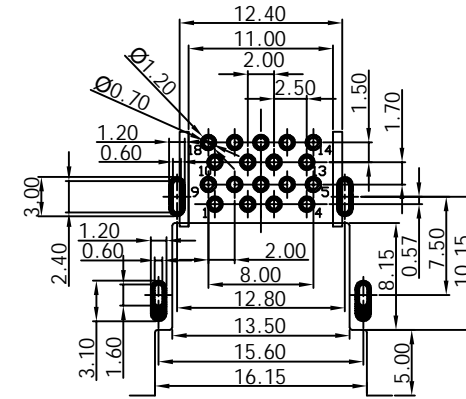

RECOMMENDED P.C.B LAYOUT
TOLERANCE: ±0.05(TOP VIEWS)

					Angle	±2°	DESIGN	Aple	2019.06.18	龍威電子有限公司 Dragon Well Ele Dragon Well Electronics Co.,Ltd		
					X.	±0.40	CHECK	Jason	2019.06.18			
					X.X	±0.35	APPROVAL	Jacky	2019.06.18			
	A-0	2019.06.18	NEW	Michael	Jacky	X.XX				TITLE:	USB 3.0 AF 双層母座沉板H=9.91mm 一体式外壳	
ECN NO.	REV	DATE	DESCRIPTION	CHANGE	APPRO.	GENERAL TOLERANCE UNLESS OTHERWISE NOTED	SCALE: N/A	UNIT:mm	A4	SHEET: 1 of 1	MODEL NO.	DW-MU3-SA18081-XXXX-01
THIS DRAWING CONTAINS INFORMATION THAT IS PROPRIETARY TO DRAGON WELL AND SHOULD NOT BE USED WITHOUT WRITTEN PERMISSION												