

RoHS COMPLIANT

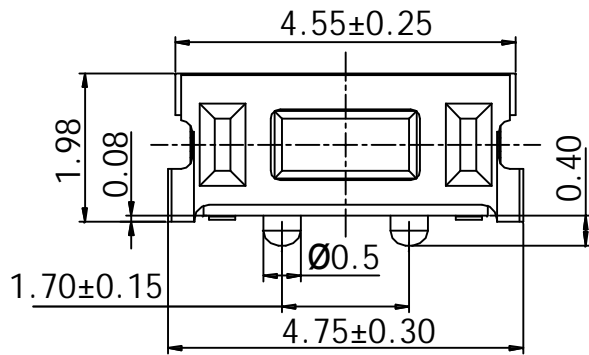
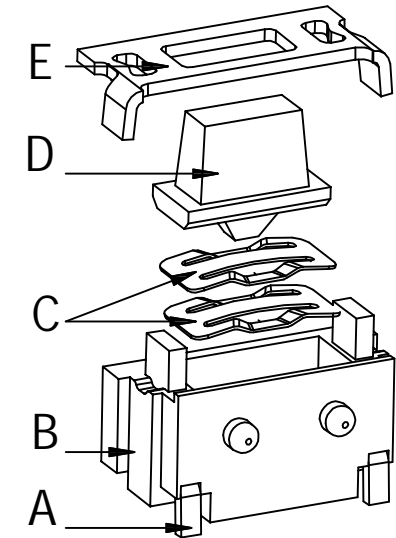
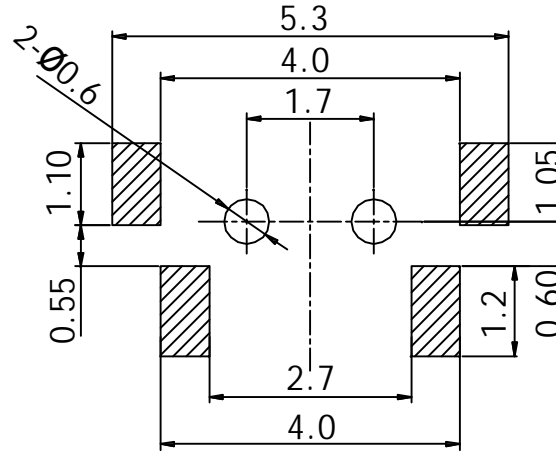
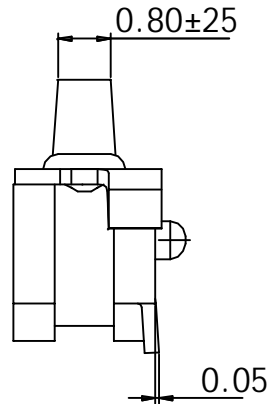
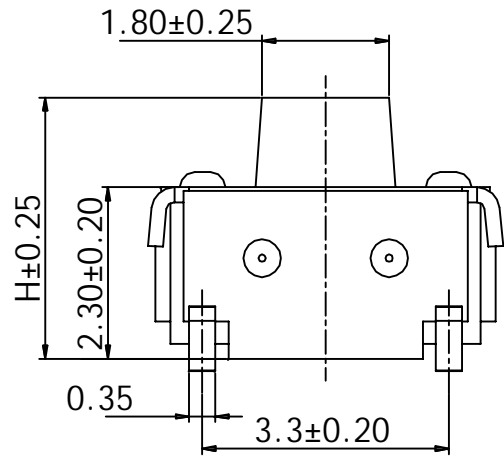
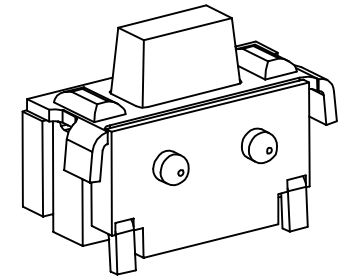

Table 1:

H	HIGH NO.
3.2	A
3.5	B
3.8	C

Remarks:

1. Rated current、Voltage: DC 12V 50mA
2. Contact resistance: $\leq 100m\Omega$
3. Insulation resistance: $\geq 100M\Omega$
4. The intensity of operations: $160\pm 50gf$
5. Life requirements: 50,000 次
6. Withstand voltage: AC 250V 1分钟



Part number Information:

DW-TS-S060180X-XX TR -02

High: X=See Table 1

TYPE	01	02
Operating Force	160±50gf	260±50gf

TR: Tape Reel

Series 01-99

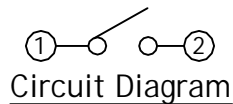

NO.	PART NAME	MATERIAL	QTY	FINISHING
E	盖板	Phospor copper	1	Ag Plating
D	按钮	LCP	1	
C	簧片	不锈钢覆银	2	
B	基座	LCP	1	
A	卡件	Phospor copper	1	Ag Plating

ECN NO.	REV	DATE	DESCRIPTION	CHANGE	APPRO.	GENERAL TOLERANCE UNLESS OTHERWISE NOTED	SCALE: N/A	UNIT:mm	A4	SHEET: 1 of 1	THIS DRAWING CONTAINS INFORMATION THAT IS PROPRIETARY TO DRAGON WELL AND SHOULD NOT BE USED WITHOUT WRITTEN PERMISSION
	A-0	2022.10.13	NEW	Aple	Rix	Angle $\pm 2^\circ$ X. ± 0.50 X.X ± 0.35 X.XX ± 0.25 X.XXX ± 0.20	DESIGN Aple 2022.10.13 CHECK Jason 2022.10.13 APPROVAL Rix 2022.10.13				龍威電子有限公司 Dragon Well Ele Dragon Well Electronics Co.,Ltd TITLE: Tact switch MODEL NO. DW-TS-S060180X-XXTR-02